

Micrometer Torque Wrenches

PRODUCT MANUAL

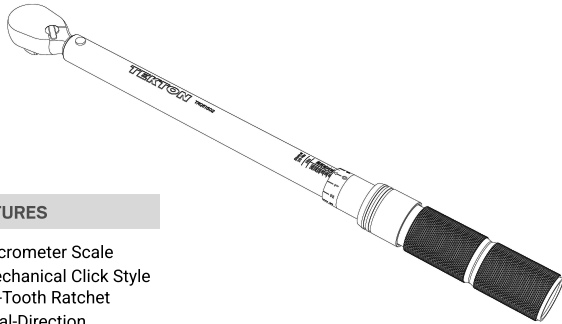

FEATURES

- Micrometer Scale
- Mechanical Click Style
- 90-Tooth Ratchet
- Dual-Direction
- +/-3% Accuracy

WRENCH MODELS

Item	Drive Size	Units	Range	Min. Increment	Overall Length
TRQ50502	1/4 in.	Nm	2–20	0.1	10.1 in.
TRQ51502	3/8 in.	Nm	20–140	1	15.6 in.

! Before using the torque wrench, we recommend you read and understand the entire manual. This tool is a precision measuring instrument that you should operate, store, and maintain with care. Failure to follow instructions could result in damage to the tool, damage to property, or injury.

- Pull the wrench slowly to observe the click.
- To maintain accuracy, store the wrench with the torque scale set to the lowest value printed on the handle body.
- Do not use the wrench as a ratchet (e.g., for breaking loose a fastener).
- If you drop or damage the wrench, test and verify its accuracy before use.

OPERATION

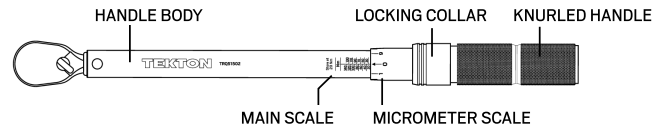

You can find the torque value at the intersection of two scales: the **Main Scale**, marked with major graduations on the handle body, and the **Micrometer Scale**, marked with fine increments and located at the top of the knurled handle above the locking collar.

SETTING THE TARGET VALUE

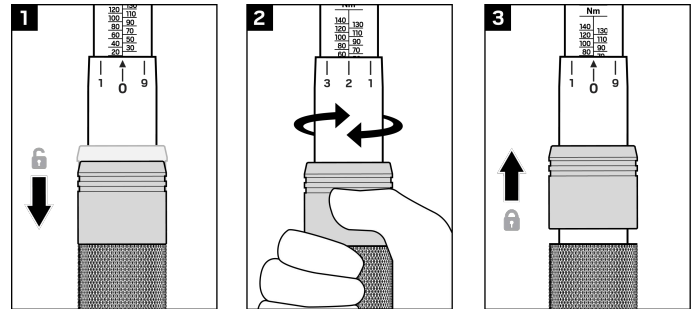

1 Pull the locking collar down fully until it rests against the knurled handle, and keep it held down during step 2.

2 Adjust the setting by turning the handle until the top edge of the knurled handle aligns with the major graduation closest to your target value. Then, fine-tune the setting by aligning the desired mark on the micrometer scale with the vertical line on the main scale.

3 Release the locking collar, then try twisting the knurled handle in both directions to confirm that it is locked at the target torque value and the collar is fully raised. The handle only locks on exact increments—not between them.

OPERATION

APPLYING TORQUE

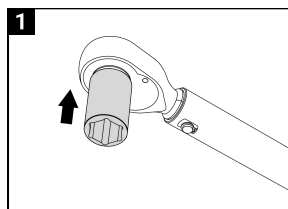

Attach a drive tool to the drive tang and engage the nut or bolt to be tightened.

! For off-axis tools, like a crowfoot wrench, calculate a leverage adjustment if needed (Page 5).

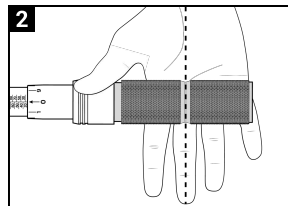

Grip the handle so your middle finger rests inside the groove in the knurling. This is where the pressure should be concentrated.

! If you don't place your hand correctly as shown, you'll get an inaccurate torque measurement. Don't use extensions on the handle—doing so produces inaccurate torque and can damage the wrench.

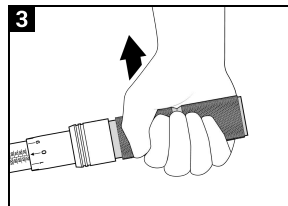

PULL the wrench **SLOWLY** with even pressure in your hand. Maintain control and be ready for a click.

! Pulling too quickly or with too much force may cause you to miss the exact torque setting. Don't bear down on the wrench with your body weight—this can cause you to overshoot your target or injure yourself.

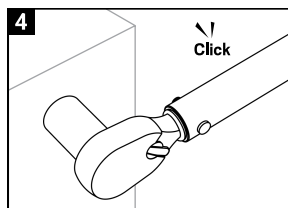

STOP applying torque as soon as you hear or feel the click. This indicates that you've reached the target torque value.

! Do not keep pulling after the click, as this can overtighten the fastener. Use extra care when working at lower torque settings.

OPERATION

INTERNAL MECHANICS

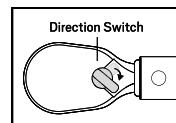
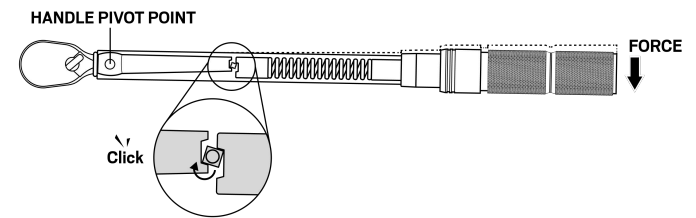

WHEN SWITCHING DRIVE DIRECTIONS:

Set the torque wrench to its lowest value before setting the target value—this allows internal components to return to a neutral position. When torque is first applied in the new direction, you may hear or feel a soft “pop” as the mechanism shifts.

MAINTENANCE AND STORAGE

- When you're not using the wrench, store it at the lowest torque value. This relieves compression on the internal spring, preventing fatigue that could affect accuracy. Do not turn the handle below this setting.
- If you haven't used the wrench regularly, operate it several times at a low torque value to allow internal lubricant to recoat moving parts.
- This wrench is a precision measuring instrument. Take care to operate it correctly and store it in a clean, dry environment.
- Clean the wrench by wiping it with a clean, dry, lint-free cloth. Do not immerse it in any type of liquid or cleaner—doing so may damage the internal components.

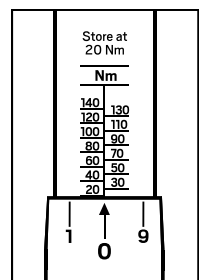

HOW TO CORRECT FOR OFF-AXIS TOOLS

Using an off-axis tool such as a crowfoot wrench or torque adapter can alter the effective length of the torque wrench. When this happens, you must adjust the target value on the wrench to ensure the correct torque is applied to the fastener.

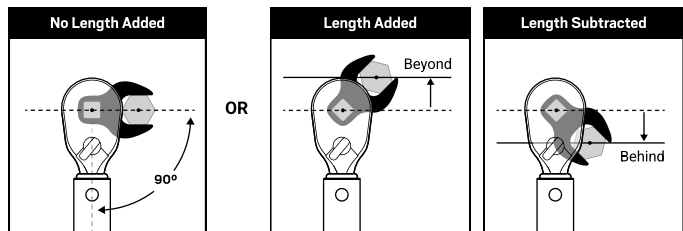

No correction is needed if the drive square and fastener are aligned at a right angle to the handle.

A correction is needed if the fastener is positioned beyond or behind the drive square, changing the effective length. Use the formula below to correct your target value.

CORRECTION FORMULA

See page 6 for a reference diagram

$$T1 \times \left(\frac{L}{L+C} \right) = T2$$

T1 – Torque specification for the fastener.

L – Effective length of the torque wrench, measured after setting the initial target value to T1.

C – Change in length caused by the drive tool extending beyond or behind the drive square.

T2 – Corrected target value you should set on the torque wrench.

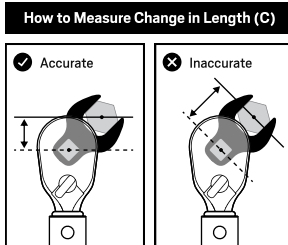

TORQUE CORRECTION EXAMPLES

$$T1 \times \left(\frac{L}{L+C} \right) = T2$$

Example 1: Length Added

$$110 \text{ Nm} \times \left(\frac{408 \text{ mm}}{408 \text{ mm} + 28 \text{ mm}} \right) = 102.9 \text{ Nm}$$

Example 2: Length Subtracted

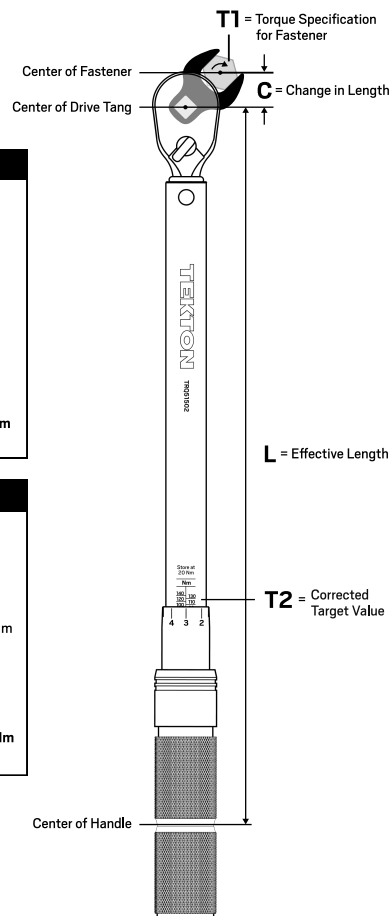
$$110 \text{ Nm} \times \left(\frac{408 \text{ mm}}{408 \text{ mm} + (-28 \text{ mm})} \right) = 118.1 \text{ Nm}$$

PARTS, ASSEMBLY, AND SERVICE KITS

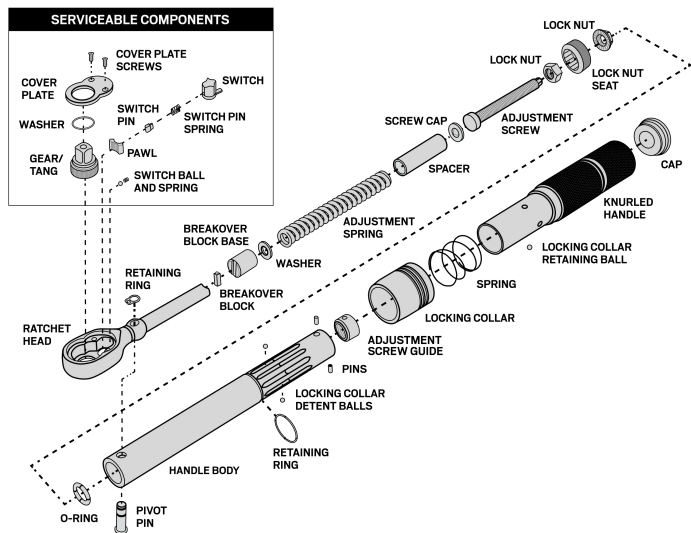

CAUTION: Only the ratcheting mechanism is user-serviceable. If you disassemble any other part of your torque wrench you may take it out of calibration. The parts and assembly may vary slightly depending on the model.

SERVICE KITS

Torque Wrench	Ratchet Service Kit
TRQ50502 - 1/4 in. Drive (2–20 Nm)	SRH9X012
TRQ51502 - 3/8 in. Drive (20–140 Nm)	SRH9X013

TORQUE UNIT CONVERSIONS

1 in-lb	1 ft-lb	1 Nm
= 0.0833 ft-lb	= 12.0000 in-lb	= 8.8507 in-lb
= 0.1130 Nm	= 1.3558 Nm	= 0.7376 ft-lb
= 0.0115 kg-m	= 0.1383 kg-m	= 0.1020 kg-m
= 1.1521 kg-cm	= 13.8255 kg-cm	= 10.1972 kg-cm

CERTIFICATE OF CALIBRATION

Each wrench is calibrated to be accurate within +/-3%.

This torque wrench has a serial number that matches a unique certificate of calibration included in the case.

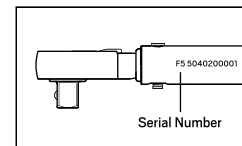

WARRANTY AND SUPPORT

We keep it simple—if your tool doesn't work like it should, let us know and we'll make it right. No time limits, no receipts, and we ship replacement parts within the United States and Canada.

CONTACT US

tekton.com/support |
 616-214-8887 |
 support@tekton.com



RESOURCE GUIDE

TEKTON®

3707 Roger B Chaffee SE • Grand Rapids, MI 49548 • Made in Taiwan

Tekton.com